



MAGNUM PLUS

Efficiency without compromise

Container Refrigeration

MAGNUM PLUS

- *Efficiency*
- *Low Environmental Impact*
- *Reliability*
- *Performance*



Specifications

System Net Cooling Capacity - Full Cool MAGNUM+ Model - Air Cooled Condensing*			
Return air to evaporator coil inlet	460/230V, 3 Phase, 60 Hz Power		
	Net Cooling Capacity		Power Consump
	60 Hz Capacity B/hr	60 Hz Capacity kW	60 Hz Power kW
21.1 °C (70 F)	54,000	16.603	11.55
1.7 °C (35 F)	42,000	11.990	11.0
-17.8 °C (0 F)	25,000	7.300	7.3
-28.9 °C (-20 F)	17,300	5.000	6.6
-35 °C (-31 F)	14,000	4.100	6.0
-40 °C (-40 F)	12,636	3.700	3.7

*System net cooling capacity with a 38 °C (100 F) ambient air temperature and R-404 A.

Dimensions	
Height	2,235 mm (88 inches)
Width	2,026 mm (79.8 inches)
Depth	420 mm (16.5 inches)
Weight	397 Kg (875 lb)

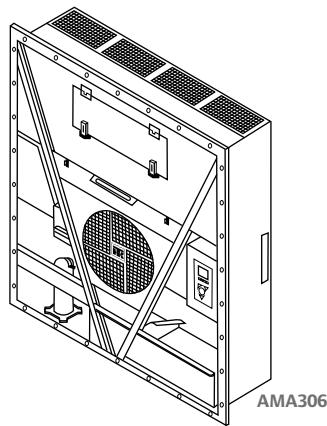

Evaporator Airflow Specifications System Net Heating Capacity*						
MAGNUM+	460/230V, 3 Phase, 60 Hz Power			380/190V, 3 Phase, 50 Hz Power		
	Heating Capacity			Heating Capacity		
	Watts	Kcal/hr	BTU/hr	Watts	Kcal/hr	BTU/hr
	5,250	4,515	17914	3,900	3,353	13,300

*System net heating capacity includes electric resistance rods and fan heat.

Insist on Genuine Thermo King Replacement Parts

Engineered to provide optimal performance and maximum life, Thermo King genuine service parts protect your investment and provide you peace of mind and confidence no matter where your equipment operates. Genuine Thermo King replacement parts are proven time after time to beat the competition in side-by-side testing. Never settle for less.

WARRANTY SUMMARY

Thermo King Warranty are available on request from your local Thermo King Dealer. Please refer to document TK50048 for the Thermo King Container unit warranty.

Efficiency without compromise

As the founder of transport refrigeration, Thermo King has always been committed to engineering innovative products and technologies and providing new levels of efficiency and performance for customers across the globe.

The MAGNUM PLUS™ is the result of years of field experience acquired with its predecessor the MAGNUM™. Through advanced technology and research & development Thermo King has introduced with the MAGNUM PLUS™ a new industry benchmark in efficiency, performance, operability and reliability. The MAGNUM PLUS™ is conceived to answer to the most stringent requirements.

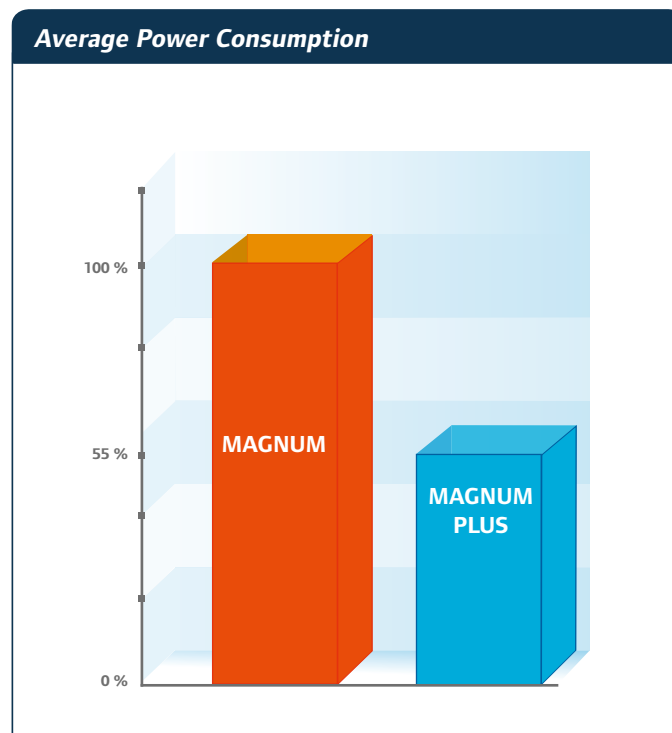

Maximum performance through efficient design

Low Energy Consumption

Less energy is required with MAGNUM PLUS™ advanced features, allowing significant cost savings and setting a new standard in efficiency.

Minimising Environmental Impact

The future is greener with MAGNUM PLUS™: thanks to its efficient operation, MAGNUM PLUS™ decreased the impact on the environment without compromising temperature control.

Lowest Temperature

The MAGNUM PLUS™ is the only unit on the market capable of reaching and maintaining -40°C box temperature in +50°C ambient environment, thereby preserving product quality and further increasing usable box life.

Tight Temperature Control

Thanks to advanced temperature management control systems, MAGNUM PLUS™ delivers extremely accurate temperature control as required in modern refrigeration.

Lower Total Cost of Ownership

The straightforward design of the system enables easy maintenance. This together with the low energy consumption ensures a low total cost of ownership. This unit not only delivers great performance, but also promises to be an ideal and profitable investment.

Faster pull down

Thanks to its superior cooling capacity, the MAGNUM PLUS™ can increase storage life by reaching the set-point faster and more accurately.

Reduced Weight

Advanced design methods and the optimization of components result in the lowest unit weight on the market, thereby significantly increasing overall cargo capacity.

Tested Technology

With over 100,000 units in service and with years of experience, the MAGNUM platform has been recognised by the industry as extremely reliable

Global Service

Thermo King global network will provide the support you need around the Globe, around the clock.

The MP-4000: A big leap forward in controller technology

User-friendly interface

A high resolution VGA graphic display allows clear and efficient visualization of all data needed in every situation. Dynamic soft- and hot-keys in the navigation menus provide immediate access to key functions.

Advanced communication capability

Interfacing capabilities with advanced telematics systems make the MP-4000 the controller of choice.

Simple and robust controller design:

- Ruggedised box
- Safety door-locking mechanism
- Simplified keyboard and menu navigation system
- Long-life, solid-state components with patented architecture
- Reduced and simplified cabling connections



Standard Features

- R-404A refrigerant
- Scroll Compressor with Digital Control Valve for capacity modulation, economizer circuit, ambient compensated internal overload and high temperature protection
- Proportional-integral differential (PID)
- Refrigeration capacity control system
- Non-corrosive maritime construction, which includes a marine-treated aluminum alloy frame, non-corrosive fittings, stainless steel hardware, condenser coil with epoxy e-coat and polyurethane top coat for UV protection, hydrophilic coating on evaporator coil, and a marine duty protective coating on the compressor
- Condenser and evaporator fan motors, which include stainless steel shafts and internal thermal overload protection
- CFC-free, foamed-in-place insulation
- Wired for 380/460 volt, three-phase, 50/60 Hz power supply with an 18 meter (60 ft) 1 1/4 power cable with CEE-17 plug
- Bottom air discharge
- Automatic electronic phase correction system
- 29 Vac control system
- On-demand defrost combined with intelligent timed defrost
- Manual defrost with initiation via MP-4000
- Indicator lights, which include Alarm, Alarm acknowledges, in range, and approaching in range
- Time delay start sequence
- Composite condenser and evaporator fans
- Conforms to ISO classifications and specifications for thermal containers, including: racking and end-loading standards, TIR specifications, ATP refrigeration standards, ARI standards for rating refrigeration capacity, UIC international Union of Railways, Australian Electrical Certification, British Standard 3755 Requirement (TAINT), USDA requirements for "Insect Cold" treatment, and Agrotechnological Research Institute (ATO-DLO) for flower bulb transportation
 - Auxiliary battery and charger
 - USDA "Cold Treatment" provision

Options

- AFAM+ Advanced Fresh Air Exchange Management
- Water Cooler Condenser
- Thermo King electronic chart recorder
- Partlow temperature recorder
- Saginomiya Temperature recorder
- Remote monitoring
- Transfresh provision
- 10/4 power cable
- De-humidification control





Thermo King Corporation, a business of Ingersoll Rand – the world leader in creating and sustaining safe, comfortable and energy efficient environments – was founded in 1938 and manufactures transport temperature control systems for a variety of mobile applications, including trailers, truck bodies, buses, shipboard containers and railway cars. The company operates 10 manufacturing facilities and 17 parts distribution centers worldwide. Sales and service is provided by a global dealer network of 865 independently owned companies in 75 countries.

europe.thermoking.com thermoking.com ingersollrand.com

For further information please contact: